

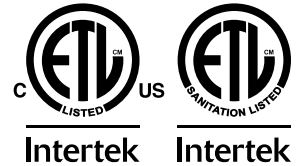

***Ice Maker***  
***Model IC-CN-0060***  
***Item 31780***  
***Instruction Manual***



*Revised - 12/07/2020*



Toll Free: 1-800-465-0234  
Fax: 905-607-0234  
Email: [service@omcan.com](mailto:service@omcan.com)  
[www.omcan.com](http://www.omcan.com)

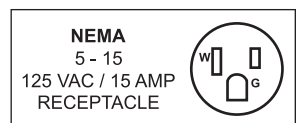

# ***Table of Contents***

Model IC-CN-0060

---

<b>Section</b>	<b>Page</b>
Disclaimer -----	3
General Information -----	4 - 5
Safety and Warranty -----	5 - 6
Technical Specifications -----	7
Installation -----	7 - 10
Operation -----	11 - 13
Maintenance -----	13 - 15
Troubleshooting -----	15 - 16
Parts Breakdown -----	17 - 18
Electrical Schematics -----	19
Notes -----	20 - 22
Warranty Registration -----	23

***OMCAN IS NOT RESPONSIBLE FOR ANY DAMAGES DUE TO WATER LEAKS. WARRANTY FOR WATER LEAKS IS VOID IF THE WICKING PAD IS NOT REPLACED EVERY SIX MONTHS, AND IF THE AMBIENT ROOM TEMPERATURE EXCEEDS 75°F AND 55% RELATIVE HUMIDITY, AND THE APPLIANCE DRAIN IS NOT CONNECTED DIRECTLY TO THE FLOOR DRAIN.***

# ***General Information***

---

**Omcan Manufacturing and Distributing Company Inc., Food Machinery of America, Inc. dba Omcan and Omcan Inc. are not responsible for any harm or injury caused due to any person's improper or negligent use of this equipment. The product shall only be operated by someone over the age of 18, of sound mind, and not under the influence of any drugs or alcohol, who has been trained in the correct operation of this machine, and is wearing authorized, proper safety clothing. Any modification to the machine voids any warranty, and may cause harm to individuals using the machine or in the vicinity of the machine while in operation.**

## **CHECK PACKAGE UPON ARRIVAL**

Upon receipt of an Omcan shipment please inspect for external damage. If no damage is evident on the external packaging, open carton to ensure all ordered items are within the box, and there is no concealed damage to the machine. If the package has suffered rough handling, bumps or damage (visible or concealed), please note it on the bill of lading before accepting the delivery and contact Omcan within 24 hours, so we may initiate a claim with the carrier. A detailed report on the extent of the damage caused to the machine must be filled out within three days, from the delivery date shown in the shipping documents. Omcan has no recourse for damaged products that were shipped collect or third party.

**Before operating any equipment, always read and familiarize yourself with all operation and safety instructions.**

**Omcan would like to thank you for purchasing this machine. It's of the utmost importance to save these instructions for future reference. Also save the original box and packaging for shipping the equipment if servicing or returning of the machine is required.**

---

**Omcan Fabrication et distribution Compagnie Limitée et Food Machinery d'Amérique, dba Omcan et Omcan Inc. ne sont pas responsables de tout dommage ou blessure causé du fait que toute personne ait utilisé cet équipement de façon irrégulière. Le produit ne doit être exploité que par quelqu'un de plus de 18 ans, sain d'esprit, et pas sous l'influence d'une drogue ou d'alcool, qui a été formé pour utiliser cette machine correctement, et est vêtu de vêtements de sécurité appropriés. Toute modification de la machine annule toute garantie, et peut causer un préjudice à des personnes utilisant la machine ou des personnes à proximité de la machine pendant son fonctionnement.**

## **VÉRIFIEZ LE COLIS DÈS RÉCEPTION**

Dès réception d'une expédition d'Omcan veuillez inspecter pour dommages externes. Si aucun dommage n'est visible sur l'emballage externe, ouvrez le carton afin de s'assurer que tous les éléments commandés sont dans la boîte, et il n'y a aucun dommage dissimulé à la machine. Si le colis n'a subi aucune mauvaises manipulations, de bosses ou de dommages (visible ou cachée), notez-le sur le bond de livraison avant d'accepter la livraison et contactez Omcan dans les 24 heures qui suivent, pour que nous puissions engager une réclamation auprès du transporteur. Un rapport détaillé sur l'étendue des dommages causés à la machine doit être rempli dans un délai de trois jours, à compter de la date de livraison indiquée dans les documents d'expédition. Omcan n'a aucun droit de recours pour les produits endommagés qui ont été expédiés ou cueilli par un tiers transporteur.

# General Information

---

Avant d'utiliser n'importe quel équipement, toujours lire et vous familiariser avec toutes les opérations et les consignes de sécurité.

Omcan voudrais vous remercier d'avoir choisi cette machine. Il est primordial de conserver ces instructions pour une référence ultérieure. Également conservez la boîte originale et l'emballage pour l'expédition de l'équipement si l'entretien ou le retour de la machine est nécessaire.

-----  
Omcan Empresa De Fabricacion Y Distribucion Inc. Y Maquinaria De Alimentos De America, Inc. dba Omcan y Omcan Inc. no son responsables de ningun daño o perjuicio causado por cualquier persona inadecuada o el uso descuidado de este equipo. El producto solo podra ser operado por una persona mayor de 18 años, en su sano juicio y no bajo alguna influencia de droga o alcohol, y que este ha sido entrenado en el correcto funcionamiento de esta máquina, y ésta usando ropa apropiada y autorizada. Cualquier modificación a la máquina anula la garantía y puede causar daños a las personas usando la máquina mientras esta en el funcionamiento.

## REVISE EL PAQUETE A SU LLEGADA

Tras la recepcion de un envio Omcan favor inspeccionar daños externos. Si no hay daños evidentes en el empaque exterior, Habra el carton para asegurarse que todos los articulos solicitados estén dentro de la caja y no encuentre daños ocultos en la máquina. Si el paquete ha sufrido un manejo de poco cuidado, golpes o daños (visible o oculto) por favor anote en la factura antes de aceptar la entrega y contacte Omcan dentro de las 24 horas, de modo que podamos iniciar una reclamación con la compañía. Un informe detallado sobre los daños causados a la máquina debe ser llenado en el plazo de tres días, desde la fecha de entrega que se muestra en los documentos de envío. Omcan no tiene ningun recurso por productos dañados que se enviaron a recoger por terceros.

**Antes de utilizar cualquier equipo, siempre leer y familiarizarse con todas las instrucciones de operación y seguridad.**

Omcan quisiera darles las gracias por la compra de esta máquina. Es de la máxima importancia para guardar estas instrucciones para referencias en el futuro. También guarde la caja original y el embalaje para envío del equipo si el mantenimiento o la devolución de la máquina es necesaria.

# Safety and Warranty

---

Please read the following instruction before operating the machine.

- Proper installation, use and maintenance of this machine are all important for maintaining production and personnel safety. In order to reduce the failure rate, please read the instructions carefully. Improper use could result in equipment damage, personal injury or even death.
- Do not use the ice maker if you have not been trained.
- Do not let children play with the ice maker or its packaging materials.

# ***Safety and Warranty***

---

- At least two people are required to lift the ice maker or it is recommended that a lifting device is used.
- A qualified and competent person must perform the installation and ongoing maintenance.
- When operating, all procedures must be followed to ensure no damage occurs to the cooling system.
- Do not operate the ice maker if there is any unauthorized changes to the original specifications of the machine, or if the machine is misused, abused or neglected.
- Ensure the ice maker's front panel and cover are in place before turning this machine on.
- Do not cover the ice-maker's vents, there must be at least 15 cm clearance around the ice maker at all times during operation.
- Do not store flammable gases or liquids near the ice maker.
- Do not use high-pressure water cleaning devices to clean the ice maker.
- It is the user's responsibility to take appropriate precautions to ensure the safety of staff using and for the ongoing maintenance of the ice maker.
- To prevent accidental injuries, keep the area clean and tidy.

## **1 YEAR PARTS AND LABOUR WARRANTY**

**Within the warranty period, contact Omcan Inc. at 1-800-465-0234 to schedule an Omcan authorized service technician to repair the equipment locally.**

**Unauthorized maintenance will void the warranty. Warranty covers electrical and part failures, not improper use.**

**Please see <https://omcan.com/disclaimer> for complete info.**

### **WARNING:**

The packaging components are classified as normal solid urban waste and can therefore be disposed of without difficulty.

**In any case, for suitable recycling, we suggest disposing of the products separately (differentiated waste) according to the current norms.**

**DO NOT DISCARD ANY PACKAGING MATERIALS IN THE ENVIRONMENT!**



# Technical Specifications

<b>Model</b>	<b>IC-CN-0060</b>
<b>Ice Production</b>	200 lbs. / 90 kgs. per day
<b>Bin Capacity</b>	70 lbs. / 31.8 kgs.
<b>Power</b>	420 W
<b>Ice Shape</b>	Cube
<b>Refrigerant</b>	R290
<b>Electrical</b>	110V / 60Hz / 1
<b>Max Ambient Temp Rating</b>	32°C / 90°F
<b>Water Temperature</b>	8° - 32°C / 46.4° - 90°F
<b>Water Pressure</b>	0.14 - 0.55 mpa
<b>Dimensions</b>	28" x 25.5" x 37.3" / 711 x 648 x 946mm
<b>Packaging Dimensions</b>	28.3" x 27.2" x 37.8" / 720 x 691 x 960mm
<b>Weight</b>	114.6 lbs. / 52 kgs.
<b>Packaging Weight</b>	127.9 lbs. / 58 kgs.
<b>Item Number</b>	31780

## Installation

### IMPORTANT

- The manual is an integrated part of the product and should be kept and preserved by the users for future reference. Please read the instructions carefully for correct installation method, safety warnings and maintenance information of the product.
- This ice maker is designed for commercial use and should be used for purpose for which it has been expressly designed. Any other use should be considered improper and therefore dangerous. The manufacturer will not be liable or responsible for any damage caused by improper, incorrect and unreasonable use.

### WARNING

The installation must be carried out by qualified personnel, in accordance with current regulations, and as per the manufacturer's instructions.

### UNPACKING

#### WARNING

Keep the packing material out of reach of children, (such as plastic bag, polystyrene, etc.)

- Remove shipping carton, tape and packing. If packing material is left in the ice maker, it will not work properly.
- After removing the packing, make sure the ice maker is in good condition. If in doubt, please do not use the

# Installation

---

ice maker but please give a call to either the seller or Omcan for advice.

- Remove shipping tape which is holding the door and front panel.
- Remove the protective plastic film from the exterior. If the ice maker is exposed to the sun or heat, remove the film after ice maker cools down.
- Remove the package of accessories, and check the content:
  - Inlet water tube.
  - Ice shovel.
  - Foot base.
  - Drain tube.
  - Plastic connector.

## LOCATION

- This ice maker is not intended for outdoor use. Normal operating ambient temperature should be within 10°C to 43°C, normal operating water temperature should be within 8°C to 32°C, operation of ice maker for extended periods, outside of these normal temperature ranges, may affect ice production capacity and performance.
- Ensure that free flow of clean air is available around the ice maker.
- The ice maker should not be located close to the heat source or exposed to the sun.
- Location should provide a firm and level foundation for the ice maker.
- Allow 15cm clearance at rear and sides for proper air circulation and ease of maintenance.
- This ice maker is not suitable for installation in an area where a water jet could be used and where water dripping is not allowed.
- To prevent damage to the water supply line, please drain the ice maker when ambient temperature is too low.

## LEVEL ADJUSTMENT OF ICE MAKER

- The level adjustment affects the ice size.

## WARNING

If the power supply cord is damaged, don't operate the machine until it is replaced by the authorized service agent or qualified technician.

## CAUTIONS

Please take protective measures when the ambient temperature is below 10°C. Faults due to the ambient temperature below 10°C are not covered by warranty.

- Place a level measurement at the machine top, adjust the machine base for front & rear, left & right balance.



## ELECTRICAL CONNECTION

### WARNING

All wiring must conform to local, state and national regulations.

- This ice maker must be plugged into an independent power source, or an electrical socket of voltage at specified range.
- This ice maker must be connected with an independent fuse / circuit breaker.

## WATER SUPPLY AND DRAIN CONNECTION

- Check if there is a need to install water treatment & filter system based on the local water situation. This can avoid the formation of precipitates, filter impurities and remove the smell of bleach.
- Water supply pressure should be minimum 0.14Mpa and maximum 0.55Mpa. If the pressure exceed 0.55Mpa use a pressure reducing valve. Do NOT bend the supply tap.
- A plumbing permit and service of a licensed plumber may be required in some area.
- Water should drain into an open trap.
- Ice maker drain is gravity flow. Please ensure drain pipe has an adequate pitch or fall.

### WARNING

Piping installation must conform to relevant regulations.

### WARNING

The machine must be plugged into a properly grounded outlet and electricity supply as per rating plate.

- To prevent a backflow into machine, please refer to the below image for installing water drain pipe.

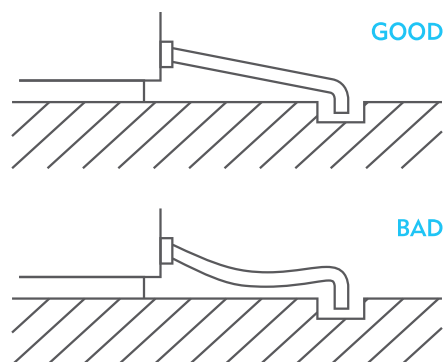

# Installation

- Attach the free end of inlet hose to the water supply tap. Hand tighten sufficiently to provide leak free joint. It is advisable to have the stop valve within easy reach.
- Hand tighten flexible water hose onto the fitting on the rear of ice maker as indicated, confirm whether the sealing ring has been tightened in the right position to avoid leaking at joints. The pipe can be cut to length as necessary to suit position of main drain. To prevent water leaks, secure.

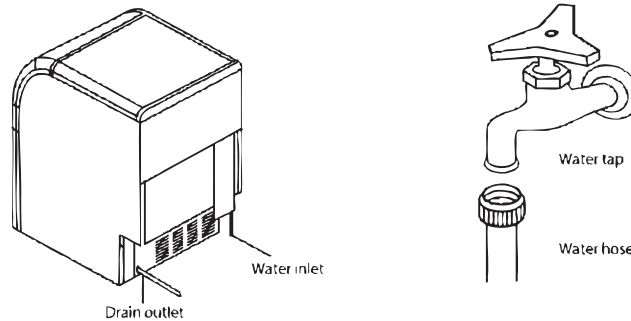

## BEFORE ICE MACHINE START

All ice machine adjustment have been factory pre-set before shipment.

Adjustment to program or setting is not required for new ice machine installation.

In order to make sure that ice machine operate normally, please refer to the operation section of service manual. Checking and monitoring of Ice machine operation is the responsibility of users.

## PRE-INSTALLATION CHECKLIST

- Is ice machine installed on a horizontal leveled surface?
- Is ice machine water pipe installed correctly?
- Have all inner packaging and accessories been removed?
- Is water supply, drain and electricity connected properly?
- Is power supply voltage matching with the specified voltage on rating plate?
- Have users/operator filled in the warranty card?
- Is there proper ventilation around ice maker for good airflow?
- Is ice machine and storage bin disinfected?
- Is ice machine grounded correctly?
- Is power switched on?
- Is ice machine located at ambient temperature between 10°C to 43°C?
- Is the inlet water temperature between 8°C to 32°C?
- Has the user / operator read this Use and Service Manual.

## CONTROL PANEL

There are three indicator lights and two key on the front control panel. The lights is for providing status information of the machine. The left key is for manual water clean function, the other key is for timer reset of air filter routine maintenance alarms for cleaning.

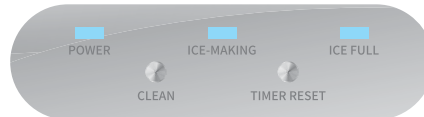

Running Status	Power Light	Ice-Making Light	Ice Full Light
Cleaning	On	Flashing	Flashing
Ice Making	On	On	Off
Ice Full	Off	Off	On
Condenser Cleaning Alarm	Flashing and Beeping	Flashing and Beeping	Flashing and Beeping

Error Status	Power Light	Ice-Making Light	Ice Full Light
Condenser Sensor Error	*	*	Flashing
Evaporator Sensor Error	*	Flashing	*
Water Shortage	One Flash One Beep	*	*
High Pressure	Two Flashes Two Beeps	*	*
Bin Full Sensor Error	Three Flashes Three Beeps	*	*
Temperature Error	Four Flashes Four Beeps	*	*
Water Level Error	Five Flashes Five Beeps	*	*
Harvest Overtime	Six Flashes Six Beeps	*	*
Ice Making Overtime	Seven Flashes Seven Beeps	*	*

## ICE THICKNESS ADJUSTMENT

Observe the first ice cube harvest and check size of the ice cubes; if an adjustment is necessary, turn the adjustment screw clockwise to increase ice thickness, counterclockwise to decrease ice thickness. Every 1/3 circle turn will increase or decrease 1.5mm as shown as below illustration.

# Operation

---

**Notice:** The screw position of ice thickness sensor determines the distance between the sensor reeds and evaporator plate. The standard gap space should be range of 4mm-7mm, please keep gap space properly.

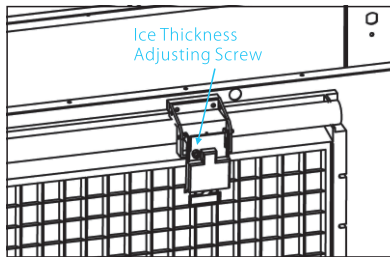

**Caution:** Do not adjust the gap out of manufactory required standard. Improper adjustment are not cover by warranty.

## WARNING

- This ice maker produces and stocks ice for use. To keep the ice maker clean and sanitary, the requirements are as follows:
  - Wash your hands before taking ice and use special ice shovel.
  - The ice maker is only used for production and storage of ice, do not store any other items in it.
  - The ice storage bin should be cleaned before use.
  - Keep the ice shovel clean. Please wash the ice shovel with neutral detergent and clean water.
  - Close the sliding door of ice storage bin after taking the ice, to prevent dirt and dust from getting into the ice storage bin.
- Please follow the basic principles while using any electrical device, points to note:
  - High humidity will increase the electrical circuit and potential risk of electric shock. If any doubt, please disconnect the ice maker from electrical power.
  - Don't pull the power cord vigorously.
  - The ice maker is not suitable for use by unattended children, the elderly or disabled.
- After shutting off the ice maker, you should wait at least 3 minutes before restart, in order to avoid any damage to the compressor.

## ICE MAKER START UP

Ice maker has been a pre-set 3 minutes cleaning programme which starts automatically after machine is switched on.

After cleaning programme, it switches over to ice making mode automatically.

## ICE MAKER PROCESSING

The water pump of ice maker will start work after water level reaches the position of high water position switch. When water level reaches low water position switch, the ice making program will start.

## ICE DROP PROCESSING

Heated refrigerant flows into evaporator which raises the temperature of the evaporator, which causes the ice drop in storage bin. When evaporator temperature reaches 25°C, the ice drop process will finish and next ice making cycle will start.

## ICE FULL

When Ice bin is full, ice level switch will switch off the ice maker and Ice Full indicator light will be ON.

When the ice level drops, the ice full switch will reset and ice maker will restart.

## TO MAKE SURE THE CONTINUOUS RUNNING OF THE ICE MAKER, PLEASE CHECK THE FOLLOWING STEPS:

- Water supply is connected and faucet is open.
- Ice maker has been connected to the electrical socket and machine switch on.
- Ice making indicator is lighting on.

## LONG TERM STORAGE OF ICE MAKER

- Turn control switch to “off” position.
- Unplug the power cord or power off the machine.
- Turn off the water supply and remove the water inlet pipe.
- Remove all ice out of the storage bin and cleaning the machine.
- Disconnect the silicone hose, to discharge water from water tank. After water drains out, reconnect the silicone hose to the correct position.

# Maintenance

---

## WARNING

- Disconnect electrical power before performing any cleaning or maintenance.
- Inspection and cleaning the condenser should be done only by a qualified service technician; at least once every year.
- Don't clean the ice maker by spraying water.
- To prevent cracks to the plastic part of ice maker, do not use any alcohol or disinfecting-type cleaners.
- Do not remove the top cover or the heat partition without authorization. Removal should be performed only by qualified service technicians.
- Clean the ice maker exterior by wiping with a clean soft cloth, at least once a week. Use damp cloth with neutral detergent to wipe off grease and dust.

## CLEAN AND DISINFECT THE SLIDING DOOR HANDLE OF ICE MAKER AND ICE SHOVEL (EVERY DAY)

# Maintenance

---

1. Fill suitable container with 3L water and 11ml sodium hypochlorite solution with concentration ratio of 5.25%, or use the special cleaning fluid.
2. Immerse ice shovel into the solution for at least 3 minutes, rinse thoroughly with water, and shake off excess water.  
**Note: Cloth containing cleaning solution may cause contamination if not disposed correctly.**
3. Clean sliding door handle of ice storage bin with a mild detergent, rinse thoroughly with water.
4. Wipe the machine with a clean cloth soaked in cleaning solution. After rinsing with water, dry it with a clean cloth.

## CLEAN AND DISINFECT THE ICE STORAGE BIN (EVERY WEEK)

1. Open the ice storage bin's sliding door, take out all the ice.
2. Clean ice storage bin by using neutral detergent which does not contain any fine particles, and then rinse thoroughly with clean water.
3. Use a clean cloth, soaked in neutral detergent to wipe inside door surface, wipe away the detergent with a clean cloth.
4. Fill suitable container with 3 QT water and 2 1/4 tsp sodium hypo chlorite solution with concentration ratio of 5.25%, or use the special cleaning fluid.
5. Immerse a clean sponge or cloth into the solution, then wipe the inside of ice storage bin and its sliding door.
6. Rinse thoroughly, then wipe away the solution completely with a clean cloth. Close the sliding door of ice storage bin.

**Note: Some solutions may cause damage or corrosion to metal parts of the ice maker inside surface.**

All the solution should be rinsed away thoroughly, unless there are additional instructions from the manufacturer or local distributors.

## AIR FILTER

The ice maker air filter prevents ash and dust in the air from clogging the condenser. An air filter blockage will reduce the ice making capacity.

Remove and clean air filter at least twice a month.

1. Remove the air filter.  
**Note: Do not put hands into the interior of machine.**
2. Clean the air filter by vacuum. If serious blockage of air filter occurs, clean the filter with neutral detergent and warm water.
3. Wash and dry air filter, then re-install to the correct location.

## ICE MAKER'S WATER SYSTEM

In order to keep the ice machine clean, we recommend regular cleaning of ice maker's water system, although this machine has automatic cleaning function.

# Maintenance

Please have water system cleaned by professional service staff.

## OUT OF SERVICE / WINTER MAINTENANCE

1. Clean and disinfect the appliance.
2. Switch off power.
3. Cut off water supply, drain off water inside. Disassemble the water inlet pipe at the back of appliance and drain off the water.
4. Spray disinfect detergent on the inside surface which is in contact with ice. Leave it until dry, no need to clean after spraying.

# Troubleshooting

If a problem arise during operation of your machine, please follow the table below before calling service.

Symptom	Possible Cause	Suggested Correction
Ice maker does not run.	No electrical power or fuse is blown.	Replace the fuse & turn switch to ON position.
	Switch on OFF position.	Turn switch to ON position, ensure "Ice making" indicator light is on.
Ice maker turns off.	Safety limited action, make the machine stop running.	Restart the switch after inspection of the electrical circuit.
Doesn't make ice or make ice slowly.	Dirty ice maker.	Clean and disinfect the ice maker.
	Locate out of horizontal leveled position.	Locate ice maker in a horizontal leveled position.
	Low ambient temperature.	The ambient temperature cannot be lower than 10°C.
	Dirty filter.	Replace the filter.
"Power" indicator flashing (No water inlet).	Water valve is closed.	Open water valve.
Ice dropping failed.	Ice dropping float ball switch is blocked.	Make sure the float ball witch is at correct position.
"Ice full" indicator flashing.	Condenser sensor error.	Replace the condenser sensor.
"Ice making" indicator flashing.	Evaporator sensor error.	Replace the evaporator sensor.
Ice cube quality is bad (Soft or dirty).	Dirty water supply.	Contact qualified service agent for water quality checking.
	Dirty water filter.	Change the filter.
	Dirty ice maker.	Clean and disinfect the ice maker.
	Drain water valve or pipe error.	Repair water drain valve or pipe.

# Troubleshooting

Ice is thin, or makes deformed ice on the evaporation.	Dirty water filter.	Replace the filter.
	Water spray & flow board dirty & blockage.	Clean water spray & flow board.
	Locate out of horizontal leveled position.	Locate ice maker in a horizontal leveled position.
	Water loss from water sink.	Check status of water drain valve whether is leaking.
Decreased ice capacity.	Dirty water filter.	Change the filter.
	Dirty condenser.	Clean the condenser.
	High ambient temperature.	The ambient temperature cannot be over 43°C.
	Insufficient space around ice maker.	Ensure enough space for ice maker.
	Too much debris around ice maker.	Clear the area around ice maker.



# Parts Breakdown

Model IC-CN-0060 31780

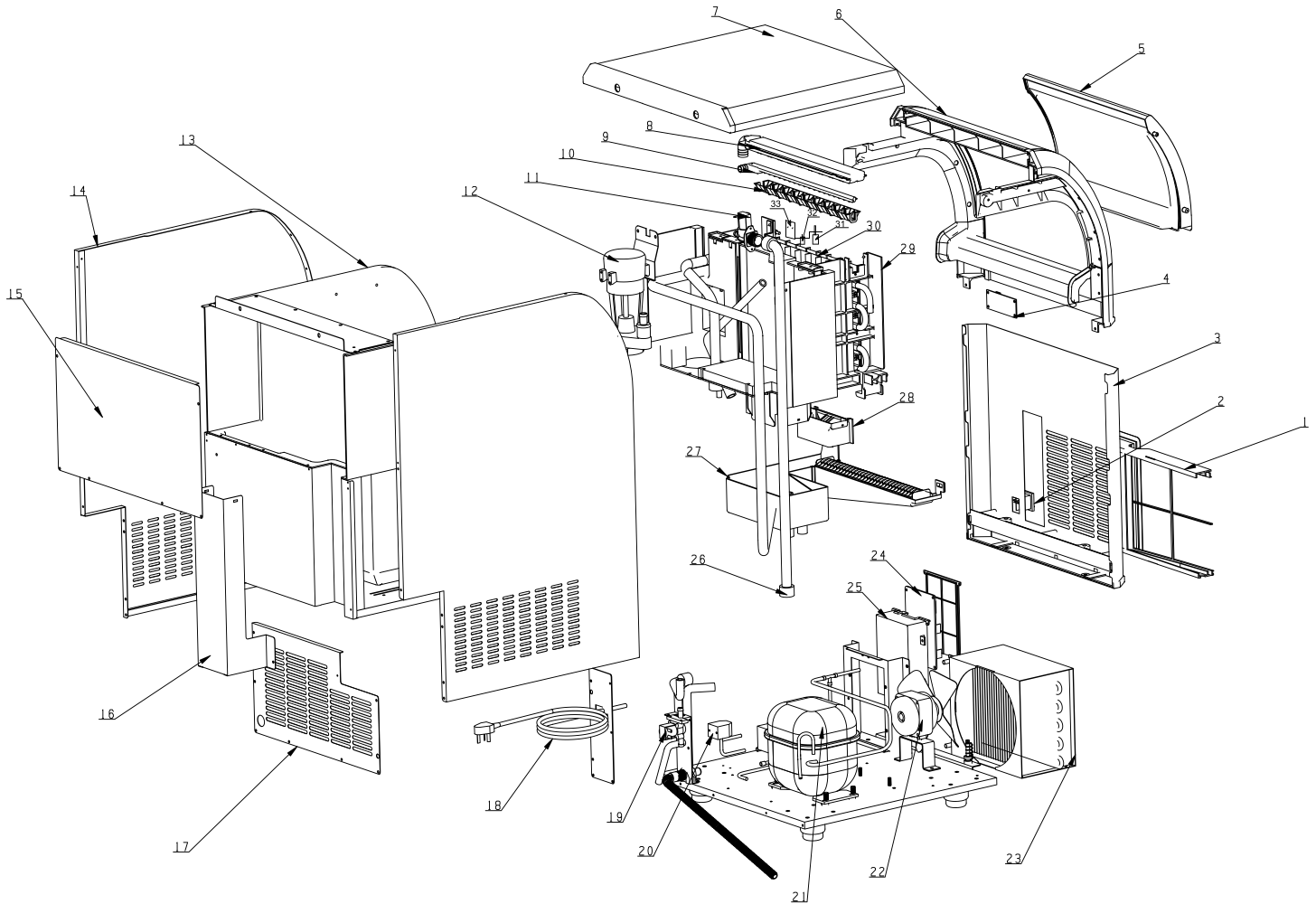

# Parts Breakdown

## Model IC-CN-0060 31780

Item No.	Description	Position	Item No.	Description	Position	Item No.	Description	Position
AC709	Air Filter for 31780	1	AC720	Water Pump for Ice Making for 31780	12	AC731	Condenser for 31780	23
AC710	Power Switch for 31780	2	AC721	Ice Bin Body for 31780	13	AC732	PCB for 31780	24
AC711	Front Panel for 31780	3	AC722	Side Panel for 31780	14	AC733	PCB Box for 31780	25
AC712	Indicator Board for 31780	4	AC723	Back Panel for 31780	15	AC734	Water Hose for 31780	26
AC713	Slide Door for 31780	5	AC724	Wire Cover for 31780	16	AC735	Water Tank for 31780	27
AC714	Door Support Frame for 31780	6	AC725	Back Panels Ventilation Plate for 31780	17	AC736	Ice Full Switch for 31780	28
AC715	Top Panel for 31780	7	AC726	Power Cord for 31780	18	AC737	Evaporator Support Assembly for 31780	29
AC716	Water Distribution Box for Ice Making for 31780	8	AC727	Water Outlet Rain Valve for 31780	19	AC738	Evaporator for 31780	30
AC717	Water Distribution Box for Water Flush for 31780	9	AC728	Solenoid Valve for 31780	20	AC739	High Water Level Sensor for 31780	31
AC718	Water Flow Guide for 31780	10	AC729	Compressor for 31780	21	AC740	Low Water Level Sensor for 31780	32
AC719	Water Inlet Valve for 31780	11	AC730	Condenser Fan for 31780	22	AC741	Water Sensor Holder for 31780	33

# Electrical Schematics

Model IC-CN-0060 31780

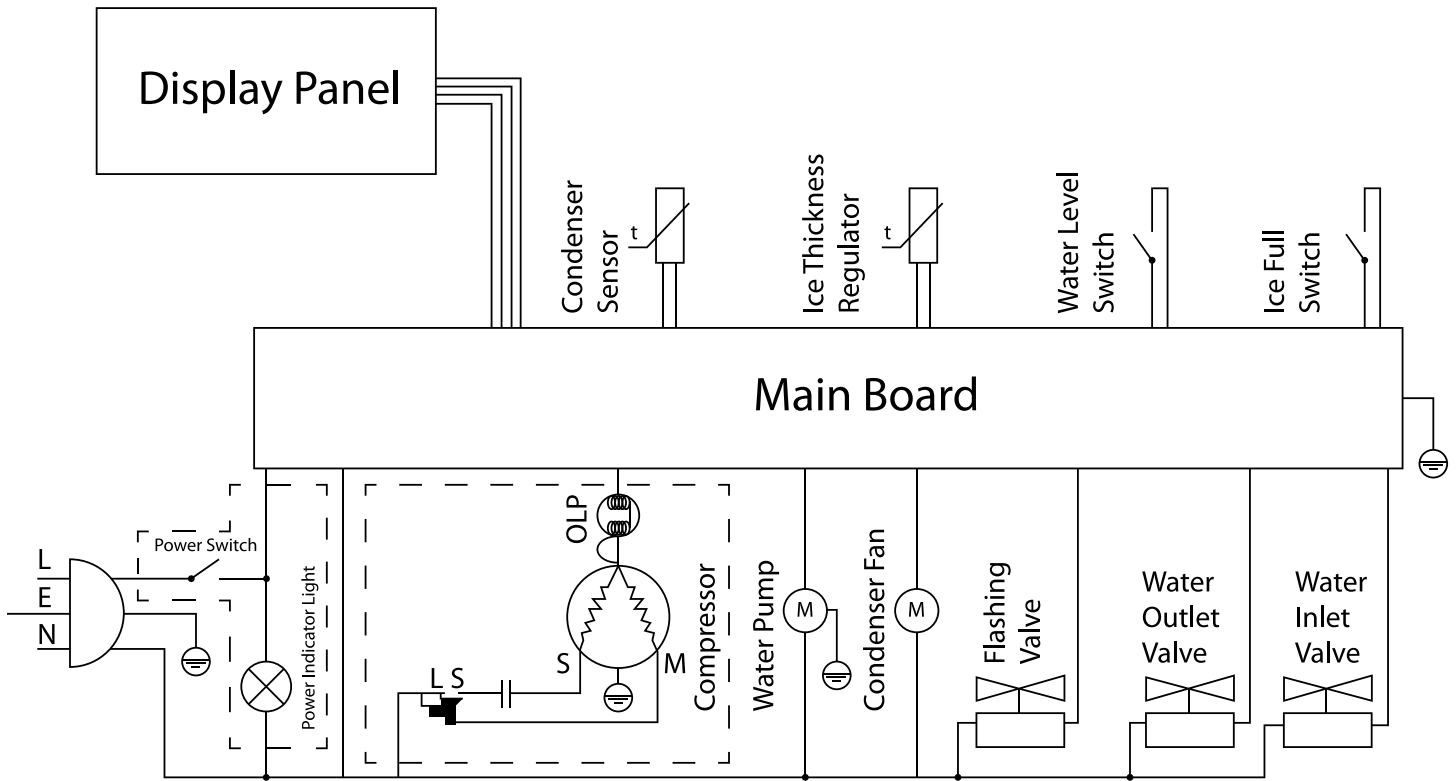





# Notes

---

---

---

---

---

---

---

---

---

---

---

---

---

---

---

---

---

---

---

---

---

---

---

---

---

---

---



# Warranty Registration

Thank you for purchasing an Omcan product. To register your warranty for this product, complete the information below, tear off the card at the perforation and then send to the address specified below. You can also register online by visiting:

Merci d'avoir acheté un produit Omcan. Pour enregistrer votre garantie pour ce produit, complétez les informations ci-dessous, détachez la carte au niveau de la perforation, puis l'envoyer à l'adresse spécifiée ci-dessous. Vous pouvez également vous inscrire en ligne en visitant:

Gracias por comprar un producto Omcan usted. Para registrar su garantía para este producto, complete la información a continuación, cortar la tarjeta en la perforación y luego enviarlo a la dirección indicada a continuación. También puede registrarse en línea en:

<https://omcan.com/warranty-registration/>

For mailing in Canada

Pour postale au Canada

Por correo en Canadá

**OMCAN**

PRODUCT WARRANTY REGISTRATION

3115 Pepper Mill Court,

Mississauga, Ontario

Canada, L5L 4X5

For mailing in the US

Pour diffusion aux États-Unis

Por correo en los EE.UU.

**OMCAN**

PRODUCT WARRANTY REGISTRATION

4450 Witmer Industrial Estates, Unit 4,

Niagara Falls, New York

USA, 14305

*or email to: [service@omcan.com](mailto:service@omcan.com)*



Purchaser's Information

Name: \_\_\_\_\_

Address: \_\_\_\_\_

City: \_\_\_\_\_ Province or State: \_\_\_\_\_ Postal or Zip: \_\_\_\_\_

Country: \_\_\_\_\_

Dealer from which Purchased: \_\_\_\_\_

Dealer City: \_\_\_\_\_ Dealer Province or State: \_\_\_\_\_

Invoice: \_\_\_\_\_

Model Name: \_\_\_\_\_ Model Number: \_\_\_\_\_

Machine Description: \_\_\_\_\_

Date of Purchase (MM/DD/YYYY): \_\_\_\_\_

Would you like to extend the warranty?  Yes  No

Company Name: \_\_\_\_\_

Telephone: \_\_\_\_\_

Email Address: \_\_\_\_\_

Type of Company:

Restaurant  Bakery  Deli

Butcher  Supermarket  Caterer

Institution (*specify*): \_\_\_\_\_

Other (*specify*): \_\_\_\_\_

Serial Number: \_\_\_\_\_

Date of Installation (MM/DD/YYYY): \_\_\_\_\_

**Thank you for choosing Omcan | Merci d'avoir choisi Omcan | Gracias por elegir Omcan**



Since 1951 Omcan has grown to become a leading distributor of equipment and supplies to the North American food service industry. Our success over these many years can be attributed to our commitment to strengthen and develop new and existing relationships with our valued customers and manufacturers. Today with partners in North America, Europe, Asia and South America, we continually work to improve and grow the company. We strive to offer customers exceptional value through our qualified local sales and service representatives who provide convenient access to over 5,000 globally sourced products.

---

Depuis 1951 Omcan a grandi pour devenir un des “leaders” de la distribution des équipements et matériel pour l’industrie des services alimentaires en Amérique du Nord. Notre succès au cours de ces nombreuses années peut être attribué à notre engagement à renforcer et à développer de nouvelles et existantes relations avec nos clients et les fabricants de valeur. Aujourd’hui avec des partenaires en Amérique du Nord, Europe, Asie et Amérique du Sud, nous travaillons continuellement à améliorer et développer l’entreprise. Nous nous efforçons d’offrir à nos clients une valeur exceptionnelle grâce à nos ventes locales qualifiées et des représentants de service qui offrent un accès facile à plus de 5000 produits provenant du monde entier.

---

Desde 1951 Omcan ha crecido hasta convertirse en un líder en la distribución de equipos y suministros de alimentos en América del Norte industria de servicios. Nuestro éxito en estos años se puede atribuir a nuestro compromiso de fortalecer y desarrollar nuevas relaciones existentes con nuestros valiosos clientes y fabricantes. Hoy con socios de América del Norte, Europa, Asia y América del Sur, que trabajan continuamente para mejorar y crecer la empresa. Nos esforzamos por ofrecer a nuestros clientes valor excepcional a través de nuestro local de ventas y representantes de los servicios que proporcionan un fácil acceso a más de 5,000 productos con origen a nivel mundial.

